

PB-950TM

Programmable Jar Tester

This Manual is for the
UEC Type Controller
ONLY.

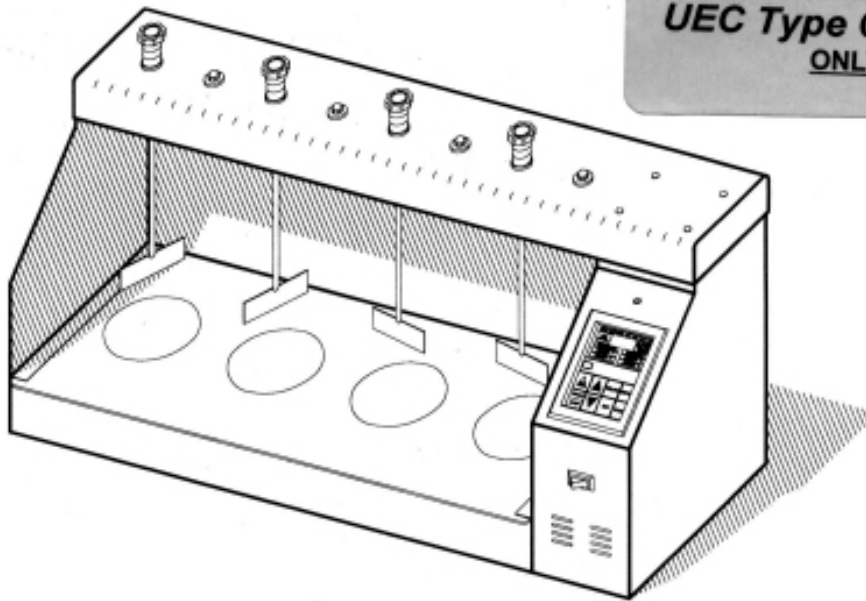

Instruction Manual

CAUTION:

DO NOT CONNECT THE EQUIPMENT TO A SOURCE OF ELECTRIC POWER AND *DO NOT* ATTEMPT TO OPERATE THE EQUIPMENT UNTIL THE INSTRUCTION MANUAL HAS BEEN READ AND UNDERSTOOD. PLEASE CONTACT PHIPPS & BIRD IF YOU HAVE ANY QUESTIONS ABOUT THE EQUIPMENT.

 **PHIPPS & BIRD**

P.O. Box 7475
1519 Summit Avenue (23230)
Richmond, Virginia 23221-0475



A STATEMENT ABOUT OUR LIMITED WARRANTY

PHIPPS & BIRD is proud of its reputation as a manufacturer of dependable products.

If you should experience any difficulty with our products, just phone, fax or write. We'll make every reasonable effort to resolve the difficulty to your satisfaction within the terms of our WARRANTY. In the United States you can reach us at 800/955-7621. Outside the U.S. you can reach us at 804/254-2737. Fax No. 804/254-2955. You may also reach us by mail at 1519 Summit Ave., Richmond, VA 23230.

Please see the last page of this manual for the complete text of the LIMITED WARRANTY. It is important that you complete and return the Warranty Card provided. This is the only way to validate your LIMITED WARRANTY coverage. The Warranty Card is self-addressed and requires no postage when mailed in the United States.

CAUTION

If the equipment is used in a manner inconsistent with that expressed by Phipps & Bird in this instruction manual, the protection provided by the equipment and the functional capabilities of the equipment may be impaired.

**NOTICE:**

When and wherever this symbol is attached to the outside of the equipment, refer to the instruction manual. Please read all applicable cautions, warnings and instructions. It is the responsibility of the operator to refer to the instruction manual to preserve the protection afforded by the equipment.

PB-950™ Programmable JarTester - Specifications

This equipment is designed to be operated under the following conditions:

- indoor use
- altitude up to 2000 m
- 5 °C to 40 °C (41 °F to 104 °F)
- relative humidity 50% - 80%
- supply voltage should not exceed +/- 10% of the nominal voltage
- transient over voltage category II

If the equipment is used in a manner inconsistent with the above environmental conditions, the protection provided by the equipment and the functional capabilities of the equipment may be impaired.

Electrical Requirements:

Model 7790-951:	120 volt AC, 60 Hz, 1 ampere
Model 7790-952:	220 volt AC, 50 Hz, .75 amperes
Model 7790-953:	220 volt AC, 60 Hz, .75 amperes

Florescent Lamp: F20T12/CW/RS

Fuse:

Model 7790-951:	1 ampere, type 3AG, slo-blo
Model 7790-952:	1 ampere, type 5x20mm, time lag
Model 7790-953:	1 ampere, type 5x20mm, time lag

Dimensions: 9-1/4"(W) x 30-1/4"(L) x 15-1/2"(H)
23.5(W) cm. x 76.8 cm.(L) x 39.4 cm.(H)

Weight: 37 lb.
16.7 kg.

Stirring Speed: 5-300 r.p.m..

Programmed Stirring Time: minimum - 1 second
maximum - 99 minutes, 59 seconds

Time Signal Frequency: minimum - every 1 minute
maximum - 98 minutes

UNPACKING INSTRUCTIONS

The PB-950™ JarTester is partially disassembled for ease in shipping and to avoid damage in shipment. Upon receipt, carefully unpack the unit and verify that the following are included in the package:

- 1 ea. PB-950™ Programmable JarTester Unit (Main assembly)
- 1 ea. Power Cord
- 4 ea. Paddles
- 4 ea. Paddle Shafts w/ knobs, adjustment collars & thumbscrews.
- 4 ea. 1000 ml. Round Laboratory Beakers
- 1 ea. Florescent Light Tube
- 1 ea. Paddle-Height Adjustment Tool

If all items are not found please contact Phipps & Bird as soon as possible.

- ☞ Save all packing material and the shipping carton if in the event your PB-950™ needs to be returned for repair or service.

What to do if shipping damage (Concealed Damage) is discovered?

The shipping carton and packaging have been specially designed to protect the equipment against damage during shipment and short-term storage.

If, upon opening the shipping carton and removing the equipment, the equipment is found to be damaged, the CARRIER must be notified immediately. The carrier will advise you what to do. The carrier may request that the damaged equipment be set aside for their inspection. If the carrier chooses to waive the inspection, a NOTICE OF WAIVER should be requested by you for your records.

If the carrier honors the damage claim, the equipment becomes its property. UNDER NO CIRCUMSTANCES SHOULD YOU DISPOSE OF DAMAGED GOODS WITHOUT WRITTEN CONSENT OF THE CARRIER.



CAUTION

DO NOT CONNECT THE EQUIPMENT TO A SOURCE OF ELECTRICAL POWER AND DO NOT ATTEMPT TO OPERATE THE EQUIPMENT UNTIL THE OPERATING INSTRUCTIONS HAVE BEEN READ AND UNDERSTOOD. SEE THE ELECTRICAL REQUIREMENTS SECTION FOR INFORMATION REGARDING THE PROPER SOURCE OF ELECTRICAL POWER. PLEASE CONTACT PHIPPS & BIRD IF YOU HAVE ANY QUESTIONS.

ELECTRICAL REQUIREMENTS

This equipment is designed to operate on nominal 120 volt, 60 Hz (cycle) or 220 Volt, 50/60 Hz AC current. Unless requested otherwise by the customer, PHIPPS & BIRD normally supplies 120 Volt, 60 Hz apparatus. The customer should examine the plug on the power supply cord. The plug types shown below are the two types used on the equipment. The number and orientation of the prongs will indicate the electrical requirements of the instrument. In addition, the electrical requirements of each unit is indicated on the serial no. label on the back of the jartester adjacent to the power (mains) receptacle.

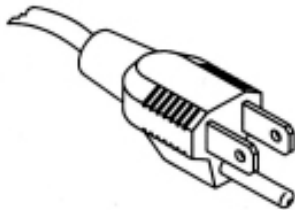

120 Volt, 50/60 Hz AC

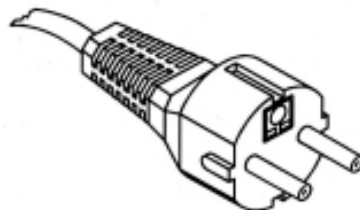

220 Volt, 50/60 Hz AC

For either 120 or 220 volts, a fused electrical supply should be used (time delay fuse or circuit breaker recommended). Although not required, it is also recommended that a separate circuit, serving only this instrument, be provided, and that an extension cord not be used. If an extension is used, it should be a three-wire type (to provide a grounding circuit).



YOUR INSTRUMENT *MUST* BE ELECTRICALLY GROUNDED.

RECOMMENDED GROUNDING METHOD

The 120 volt power supply cord is provided with a three-pronged grounding plug, which should be plugged into a mating grounding type receptacle in accordance with National Electrical Code and applicable local codes and ordinances. When a proper grounding type receptacle is not available, the existing receptacle should be changed to the proper receptacle and grounded in accordance with applicable codes.



DO NOT UNDER *ANY* CIRCUMSTANCES, REMOVE THE POWER PLUG'S GROUND PRONG. DO NOT OPERATE THE EQUIPMENT IF THE GROUND PRONG IS MISSING.

The 220 volt power supply cord is provided with a CEE 7/7 standard two-prong plug which should be plugged into a mating grounding type receptacle in accordance with the ordinances of the safety agencies of the local community, province, state or country. When a proper grounding type receptacle is not available, the existing receptacle should be changed to the proper receptacle and grounded to earth. Phipps & Bird suggests that the operator DOES NOT attempt to use a grounding adapter for use with a 220 volt unit.

ALTERNATE GROUNDING METHOD(120 Volt AC)

If changing and properly grounding the receptacle is impossible and where local codes permit (consult your electrical inspector), a grounded adapter may be plugged into the existing three-pronged electrical power supply receptacle.

To ground the adapter, the plug of the green wire on the adapter must be connected to the receptacle cover plate screw. From this same screw a separate ground wire must be connected to a grounded cold water pipe which has metal continuity to electrical ground, uninterrupted by plastic, rubber or other electrically insulating connectors (see figure below).



CAUTION: DO NOT GROUND TO A GAS SUPPLY PIPE.

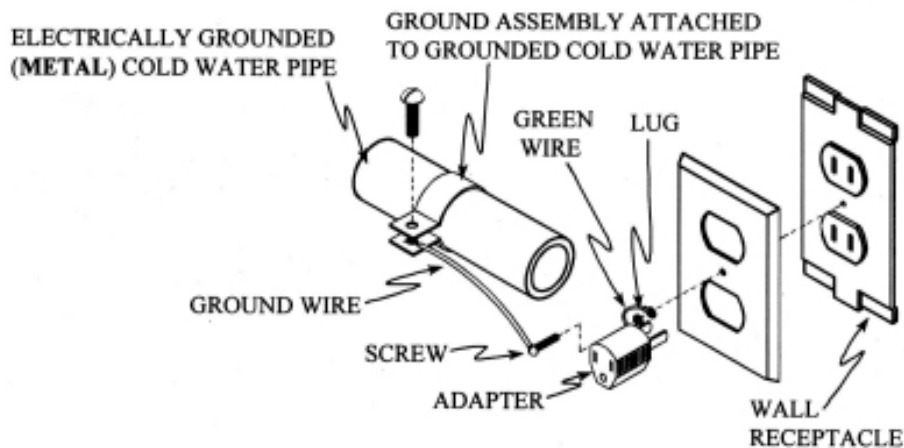

ASSEMBLY INSTRUCTIONS

Select a reasonably level, stable surface for locating the PB-950™ JarTester. The JarTester should be located with access to electrical power as described in **ELECTRICAL REQUIREMENTS**. When placing the JarTester allow at minimum of 2" (50 cm) between the back of the JarTester and any wall or structure. Do not block the ventilation holes on the back of the JarTester.

POWER CORD ASSEMBLY

Unpack the power cord and insert the chassis end of the cord into the POWER (Mains) RECEPTACLE on the stirrer frame (see adjacent figure). Insert the plug completely into the receptacle so as to make full electrical contact.

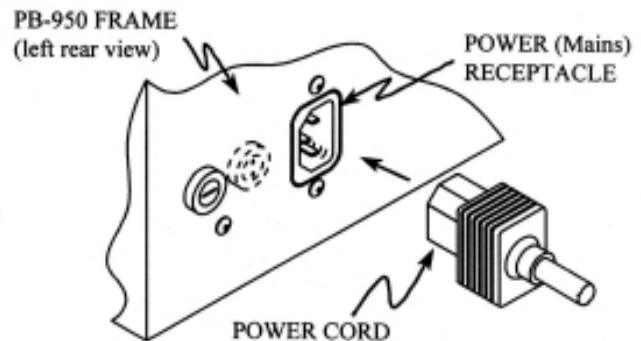

PADDLE ASSEMBLY

Unpack the four (4) PADDLE SHAFTS and four (4) PADDLES. Insert a PADDLE SHAFT into a DRIVING DOG on the JarTester. Ensure that the HEIGHT ADJUSTING COLLAR is engaged with the PIN on the DRIVING DOG. Hold the PADDLE SHAFT by the KNOB and screw the PADDLE onto the bottom of the PADDLE SHAFT. Tighten the PADDLE until snug, but do not tighten to the point that it will be difficult to remove. Repeat for all four (4) paddles (see adjacent figure).

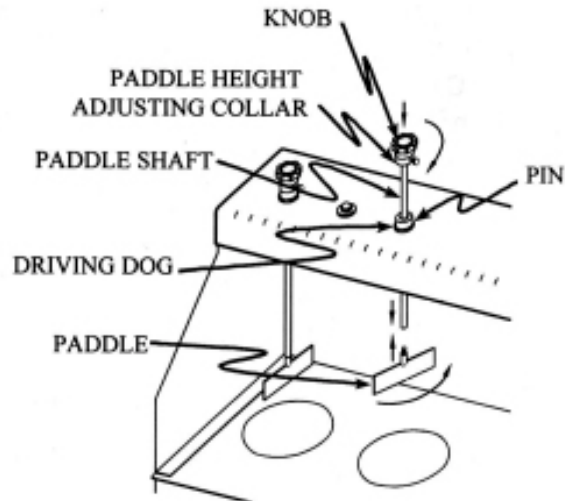

CONTROL PANEL

INDICATORS

The INDICATORS are color coded to match their respective control buttons. The "green" lettered INDICATORS are controlled by the DISPLAY control button and the "blue" lettered INDICATORS controlled by the SELECT control button. (See CONTROL BUTTON section.)

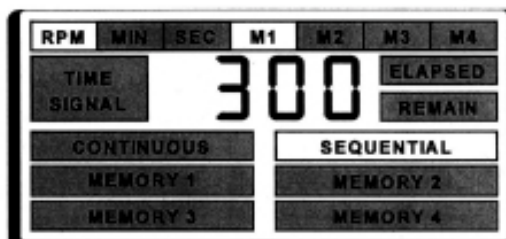

All INDICATORS are "highlighted" in grey in the "on" or indicating state and are black in the "off" or non-indicating state. For example, in the above figure RPM, M1 and SEQUENTIAL are in the "on" or indicating state.

The seven bars across the top (RPM, HRS, MIN, M1, M2, M3, M4) are highlighted when programming and displaying in the SEQUENTIAL and MEMORY modes. For example, in the above figure the JarTester is operating in SEQUENTIAL mode with M1(MEMORY 1) controlling the stirring. (Note: M1, M2, M3 and M4 refer to MEMORY 1, MEMORY 2, MEMORY 3 and MEMORY 4 respectively.)

RPM, MIN, SEC, and TIME SIGNAL, when highlighted, indicate what the DIGITAL DISPLAY is showing. RPM indicates stirrer speed in revolutions per minute; MIN indicates stirring time in minutes; SEC indicates stirring time in seconds and TIME SIGNAL indicates frequency of the audible alarm in minutes (red LED also lights when the alarm sounds). For example, in the above figure, RPM is indicating a stirring speed of 300 revolutions per minute.

M1, M2, M3 and M4 indicate which memory is controlling stirrer operation. CONTINUOUS, SEQUENTIAL, MEMORY 1, MEMORY 2, MEMORY 3 and MEMORY 4 indicate what mode the JarTester is operating under. In the above figure, the JarTester is in SEQUENTIAL memory mode with M1(MEMORY 1) controlling the stirring.

The ELAPSED and REMAIN bars, when highlighted, indicate how much time has elapsed or remains during a memory operation.

DIGITAL DISPLAY

The digital display (shown as 300 in above drawing) will show the value of the highlighted INDICATOR (RPM, MIN, SEC, TIME SIGNAL, ELAPSED and REMAIN) when programming or when the JarTester is operating

CONTROL BUTTONS



MACRO ADJUSTMENT - Each press of this button increases stirrer speed or time (Min or Sec) setting by a value of fifty.



UP ADJUSTMENT - Each press of this button increases stirrer speed or time (Min or Sec) setting by a value of one (1). Also, holding this button down will rapidly increase the stirrer speed or speed setting.



DOWN ADJUSTMENT - Each press of this button decreases stirrer speed or time (Min or Sec) setting by a value of one (1). Holding the button down will rapidly decrease the stirrer speed and/or speed setting.

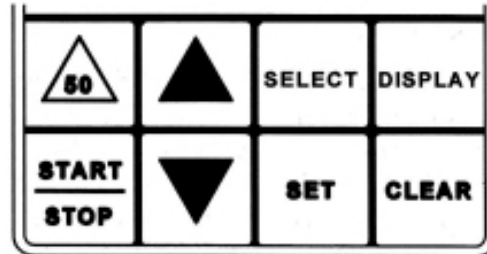

START/STOP - Each press of the button will alternately start and stop the stirring operation.



SELECT- Controls the selection of the operating mode to be programmed. Each press of the button "steps" through the CONTINUOUS, SEQUENTIAL, MEMORY 1, MEMORY 2, MEMORY 3 and MEMORY 4 modes respectively.



DISPLAY - Controls the selection of programming parameters for each operating mode. Each press of the button "steps" through RPM, MIN, SEC, and TIME SIGNAL when programming. In MEMORY or SEQUENTIAL mode, with the JarTester running (stirring), pressing DISPLAY "steps" through RPM, ELAPSED AND REMAIN and shows the current speed in RPM, the elapsed time and the remaining time in minutes and seconds respectively for that particular operating mode. In CONTINUOUS mode, this button does not function.



SET- Enables the highlighted parameter (RPM, MIN, SEC, and TIME SIGNAL) to be programmed or "set". When a "displayed" parameter is enabled to be "set" it's indicator will flash.



CLEAR- Pressing this button will clear all memory parameters (RPM, MIN, SEC) for a "selected" memory (MEMORY 1, MEMORY 2,) when any of its associated parameter is "displayed" and in the flashing "set" mode.

OPERATING INSTRUCTIONS

The PB-950™ JarTester is a multi-functional stirring apparatus capable of operating in a non-programmed (CONTINUOUS) or programmed (MEMORY 1-4, SEQUENTIAL) mode.

CONTINUOUS Mode

In the CONTINUOUS mode, the stirring speed (5-300 r.p.m.) is set, then the stirring is "started" and the stirrer operates until the stirring is "stopped". Stirrer speed can be adjusted up or down while the stirrer is running. To operate the JarTester in continuous mode follow these steps:

1. Turn the power switch "on".
2. Push **SELECT** button until **CONTINUOUS** is highlighted with a grey background.
3. With the **UP▲**, **DOWN▼** and **MACRO△** buttons enter a desired speed.
4. Press the **START/STOP** button to start the stirrer.
5. The stirrer speed may be adjusted with the **UP▲**, **DOWN▼** and **MACRO△** buttons while the paddles are turning. Speed may be adjusted from 5 to 300 revolutions per minute.
6. Press the **START/STOP** button to stop the stirrer.

Programming MEMORY 1,2,3 & 4

Each memory can be programmed with a "set" speed (5-300 r.p.m.), timed duration of stirring (1 second to 99 minutes, 59 seconds), and optional timed signal (frequency in minutes, 1-98 minutes). Each memory can operate alone or sequentially (see below). To program and operate an individual memory follow these steps:

1. Turn the power switch "on".
2. With the stirrer stopped, use the **SELECT** button to choose the desired memory (1,2,3 or 4). Press **SELECT** until desired memory is highlighted in grey.
3. Press **DISPLAY** until **RPM** is highlighted in grey. Press **SET** and **RPM** will flash. Enter the desired **RPM** using the **UP▲**, **DOWN▼** and **MACRO△** buttons.
4. Set time duration in minutes (MIN) and seconds (SEC).
 - Press **DISPLAY** until **MIN** is highlighted in grey. Press **SET** and **MIN** will flash. Enter the time interval in minutes using the **UP▲** and **DOWN▼** buttons.
 - Press **DISPLAY** until **SEC** is highlighted in grey. Enter the time interval in seconds using the **UP▲** and **DOWN▼** buttons.
5. Set **TIME SIGNAL** in minutes (optional).
 - Press **DISPLAY** until **TIME SIGNAL** is highlighted in grey. Press **SET** and **TIME SIGNAL** will flash. Enter the desired **TIME SIGNAL** interval in minutes using the **UP▲** and **DOWN▼** buttons.
6. Press **DISPLAY** to stop any **INDICATOR (RPM, MIN, SEC and TIME SIGNAL)** from flashing. Press **START/STOP** and programmed **MEMORY (1,2,3 or 4)** will begin.

SEQUENTIAL Mode

The SEQUENTIAL mode is the most beneficial mode when performing a jar test or any stirring procedure which requires changes in the stirring speed at timed intervals. The SEQUENTIAL mode, when started, executes the programmed memories (1-4) in numerical order.

1. Turn the power switch "on".
2. Program memories (1,2,3 and/or 4) with speed (RPM) and time (MIN, SEC) settings into controller. See above.
3. Press **SELECT** until **SEQUENTIAL** is highlighted in grey.
4. Press **START/STOP** to begin stirring. The PB-950™ will execute all memories (1-4) in order and then stop.
5. The operator may press **START/STOP** to stop the stirrer at any time during the **SEQUENTIAL** program. Stopping the stirrer during a sequential operation will reset the programming back to **MEMORY 1** when the stirrer is restarted.

EXAMPLE PROGRAM

This section is intended to give a step-by-step instruction on programming a typical jar test procedure. Your jar test procedure may be different. However, if the operator follows this example he or she should be well acquainted with the programming features so that they can substitute their parameters (speed in r.p.m., time in minutes and seconds) and perform their own unique jar test. This example procedure is merely given as a means of showing how quickly and easily the operator can program their unique procedure.

Example procedure:

Flash Mix:	295 r.p.m. for 1 minute and 15 seconds.
Floc Mix:	25 r.p.m. for 5 minutes.
Settling Period:	0 r.p.m. (no agitation) for 10 minutes. Samples will be taken for examination every 2 minutes

The flash mix will be programmed as Memory 1, the Floc Mix will be programmed as Memory 2 and the Settling Period will be programmed as Memory 3. For this example, Memory 4 will not be programmed as it is not needed and will be cleared to insure it will not operate. To program the above procedure follow these steps:

1. Press power switch on front panel to 'on' position.
2. Press **SELECT** button twice until **MEMORY 1** indicator is highlighted. (RPM indicator will also be highlighted.)
3. Press **SET** and the **RPM** indicator will flash.
4. Press **▲** button until "300" appears on the digital display. Press the **DOWN ▼** button until the digital display reaches "295".
5. Press **DISPLAY** once. **MIN** will now be highlighted and **RPM** will stop flashing. Press **SET** and **MIN** will flash.

6. Press the **UP▲** button until "1:00" appears on the digital display.
7. Press **DISPLAY** once. **SEC** will now be highlighted and **MIN** will stop flashing. Press **SET** and **SEC** will flash.
8. Press the **UP▲** button until the digital display shows "1:15".
9. Press **DISPLAY** once and **TIME SIGNAL** will be highlighted and **SEC** will stop flashing. The **DIGITAL DISPLAY** should show "0". (**TIME SIGNAL** will be used to warn the operator to take samples during the Settling Period or **MEMORY 3**.)
10. Press **SELECT** once until **MEMORY 2** indicator is highlighted. (**RPM** indicator will also be highlighted.)
11. Press **SET** and the **RPM** indicator will flash.
12. Press the **UP▲** button until "25" appears on the digital display.
13. Press **DISPLAY** once. **MIN** will now be highlighted and **RPM** will stop flashing. Press **SET** and **MIN** will flash.
14. Press the **UP▲** button until "5:00" appears on the digital display. **SEC** and **TIME SIGNAL** will not be programmed as they are not needed for the Floc Mix or **MEMORY 2**.
15. Press **SELECT** once until **MEMORY 3** indicator is highlighted. (**RPM** indicator will also be highlighted.)
16. Press **DISPLAY** once and **MIN** will be highlighted. Press **SET** and **MIN** will flash.
17. Press the **UP▲** button until "10" appears on the digital display.
18. Press **SELECT** twice until **TIME SIGNAL** is highlighted. Press **SET** and **TIME SIGNAL** will flash.
19. Press the **UP▲** button until "2" appears on the digital display. (During the Settling Period an audible alarm will sound and the red LED on the front panel will light every two minutes to signal the operator it is time to draw samples.)
20. **MEMORY 4** is not needed for this jar test procedure and we will clear it's parameters. Press **SELECT** once until **MEMORY 4** indicator is highlighted. (**RPM** indicator will also be highlighted). Press **SET** and **RPM** will flash. Press **CLEAR** and all **MEMORY 4** parameters will go to zero.
21. Press **SELECT** twice until **SEQUENTIAL** is highlighted. Press **START/STOP** and the PB-950™ JarTester will perform the example procedure outlines above.
22. Press **DISPLAY** while the program is operating and the digital display will switch between displaying the **RPM**, **ELAPSED** and **REMAIN** time. The highlighted indicator will identify what is being displayed.

The individual memories (1,2,3, & 4) are now stored in the controller until they are changed or are cleared as was done for **MEMORY 4** in step 20 of the above example procedure. (Note: Turning the JarTester 'off' or unplugging the JarTester from a power source does not erase the programming. Only by changing or clearing a memory will any parameter be altered). In addition, each individual memory may be operated alone. For example, if the operator wished to perform only the Flash Mix as described above, all that would be required (once programmed) is to press **SELECT** until **MEMORY 1** is highlighted and then **START/STOP** and the JarTester would perform **MEMORY 1** and only that memory.

ADJUSTING PADDLE HEIGHT

The paddles on the PB-950™ can be raised and lowered by means of the PADDLE HEIGHT ADJUSTING COLLARS. To raise or lower the paddles :

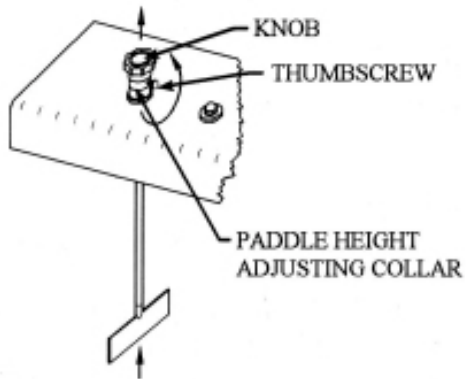

1. Grab KNOB and raise paddle.
2. Turn THUMBSCREW counterclockwise and loosen PADDLE HEIGHT ADJUSTING COLLAR from paddle shaft.

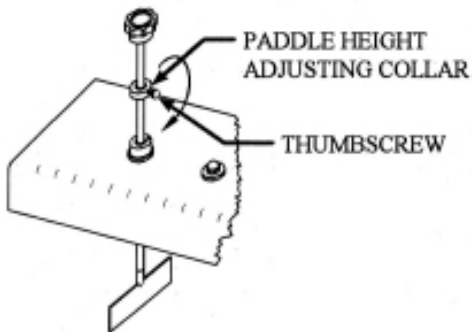

3. Set PADDLE HEIGHT ADJUSTING COLLAR at desired height and tighten THUMBSCREW to paddle shaft.

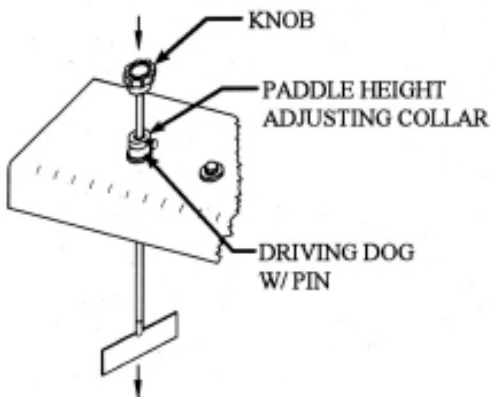

4. Lower KNOB until PADDLE HEIGHT ADJUSTING COLLAR engages with PIN on DRIVING DOG.

MAINTENANCE

The PHIPPS & BIRD PB-950™ Programmable JarTester is designed and constructed to provide long-term service with a minimum of maintenance. The operator should only need to perform the following:

- **LUBRICATE BEARINGS.** Lubricate the Paddle Bearings and the Idler Bearings at least once a year. A good quality multi-purpose, lightweight (SAE 10 or 15) oil is satisfactory. A small drop is sufficient. No disassembly is required to perform this simple maintenance. See lubrication points in figure below.
- **REPLACE ILLUMINATOR LIGHT TUBE (see figure below).**

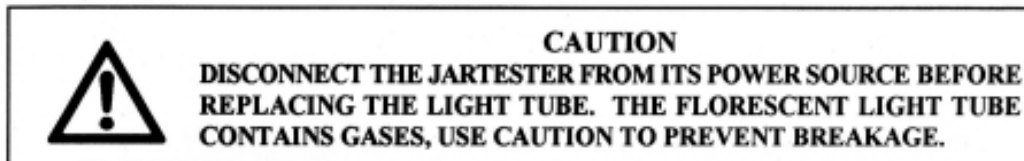

After extended use the florescent LIGHT TUBE may burn out and will require replacement. (For 220 volt models, PB-952 & PB-953, remove ILLUMINATOR TOP hold down screws. Screws are located at the front edge of the ILLUMINATOR TOP.) Using both hands, slide the ILLUMINATOR TOP and the ILLUMINATOR PANEL from the JarTester frame. Grasp the LIGHT TUBE and turn approximately one-quarter turn so that the pins on the end of the LIGHT TUBE align with the slots on the FLORESCENT SOCKET. Lift the old LIGHT TUBE from the FLORESCENT SOCKETS and discard tube. Replace new tube by sliding end-pins of LIGHT TUBE into slots on the FLORESCENT SOCKETS. Turn tube approximately one-quarter turn until tube fits snugly in fixture. Slide the ILLUMINATOR TOP and the ILLUMINATOR PANEL back into place into the JarTester frame. (220 volt models only: replace the ILLUMINATOR TOP hold down screws)

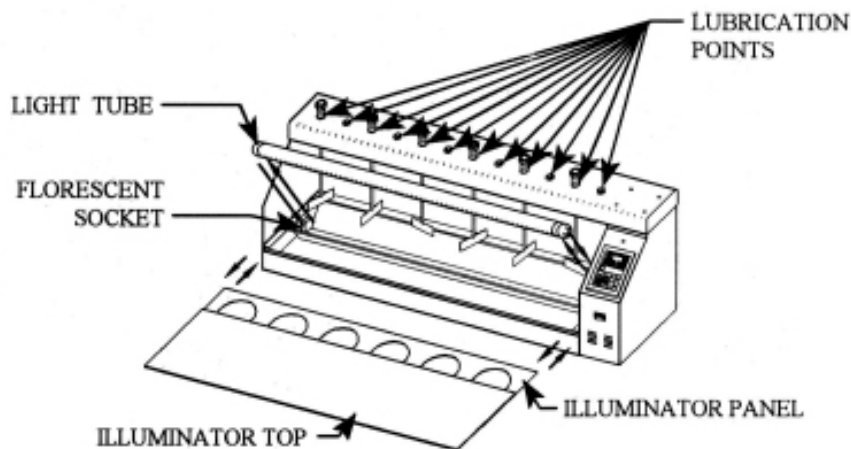

REPLACE FUSE. The FUSE(s) on your PB-950™ Programmable JarTester may on occasion require replacement. The JarTester will not function if the FUSE is blown or defective. To check to see if a FUSE is defective, first unplug the POWER CORD from the MAINS RECEPTACLE. Locate the FUSE HOLDER(s) on the back of the JarTester unit (see adjacent figure). Use the small flat blade SCREWDRIVER included with your JarTester and insert the blade into the slot on the FUSE CARRIER. Push the FUSE CARRIER in and make a 1/4 counter-clockwise turn until the carrier releases from the FUSE HOLDER and springs out. The FUSE CARRIER and FUSE can now be removed. Remove the FUSE from the carrier and check to see if the FUSE has a "break" or appears "blown". If the fuse appears defective, replace it with a 1 amp, type 3AG Slo-Blo Fuse.

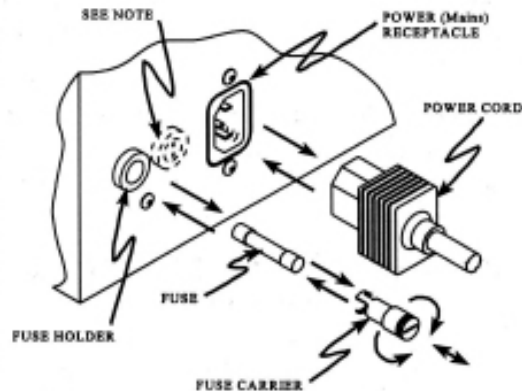

Note: 220 volt JarTesters require two (2) 1 amp, type 5x20mm Time Lag fuses.

To replace the new or old fuse(s), insert the FUSE in the FUSE CARRIER. Insert the fuse and carrier into the FUSE HOLDER. Insert the flat blade screwdriver into the slot on the carrier and gently push while turning clockwise until the carrier recedes into the carrier and locks in place. Reinsert the POWER CORD into the POWER RECEPTACLE. The JarTester is now ready for use.



DO NOT ATTEMPT TO SERVICE THE ELECTRONIC COMPONENTS. ANY REQUIRED MAINTENANCE TO THE PROGRAMMABLE CONTROLLER AND IT'S ELECTRONICS MUST BE PERFORMED BY A PHIPPS & BIRD TECHNICIAN.

- **CLEANING.** Use a mild household detergent when cleaning the PB-950™ JarTester. Disconnect the JarTester from its power source. Dampen a cloth with the cleaner and wipe the soiled area of the JarTester. Allow the unit to dry before reconnecting to its power source.



CAUTION:

DO NOT ATTEMPT TO EMERGE THE JARTESTER IN WATER OR LIQUID WHEN CLEANING OR OTHERWISE. DO NOT POUR LIQUIDS INTO OR ONTO THE JARTESTER. IF WATER OR ANY LIQUIDS ARE SPILLED ONTO OR INTO THE JARTESTER, UNPLUG THE UNIT FROM ITS POWER SOURCE IMMEDIATELY. WIPE ALL ACCESSIBLE LIQUIDS WITH A DRY CLOTH AND THEN ALLOW FOR ALL LIQUIDS TO DRY BEFORE PLUGGING THE UNIT TO ITS POWER SOURCE

REPLACEMENT PARTS LIST

ITEM NO.	DESCRIPTION	PART NUMBER
Paddle and Gear Train:		
1	Paddle Knob	351000010
2	Paddle Height Adjusting Collar	977904020
3	Driving Dog	977904014
4	Paddle Gear and Shaft	977904012
5	Paddle Shaft	100023302
6	Paddle Blade with Stem	977909008
7	Acorn Nut, 1/4-28	383025028
8	Washer	803025020
9	Idler Gear and Shaft	977904013
Misc:		
	Acrylic Illuminator Top	977909503
Note: ITEM NO. refers to the numbered items in the adjacent figure.		

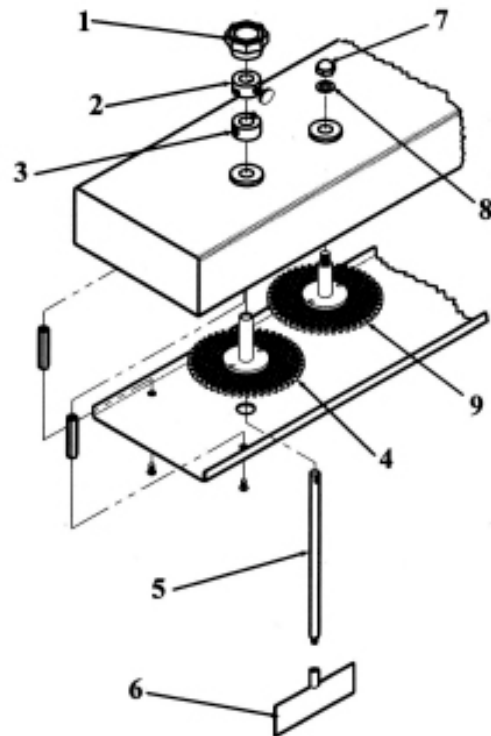

LIMITED WARRANTY

Phipps & Bird ("the Company") warrants that this equipment will be free from defects in material and workmanship under normal use and service for a period of one (1) year from the date of shipment. This warranty extends solely to the registered owner and may not be assigned or otherwise transferred to any other person. The owner must register within 30 days from the date the equipment was purchased. The Company's liability under this warranty is limited solely to replacing or repairing, at the discretion of the Company, the equipment that is defective; provided, however, that the Company shall not be liable under this warranty unless (a) the Company is notified promptly in writing, at the address printed on the warranty card, by the owner, upon the discovery of a defect, (b) if requested by the Company, defective equipment is promptly returned to the Company, and (c) the Company determines that the malfunction of the equipment was not caused by misuse, neglect, improper installation, repair, alteration or accident. IN NO EVENT SHALL THE COMPANY BE LIABLE TO THE OWNER OF THE EQUIPMENT FOR LOSS OF PROFITS, LOSS OF USE, SPECIAL, INCIDENTAL OR CONSEQUENTIAL DAMAGES OR DAMAGES OF ANY KIND BASED UPON A CLAIM FOR BREACH OF WARRANTY, OTHER THAN THE PURCHASE PRICE OF ANY DEFECTIVE EQUIPMENT COVERED HEREUNDER. This warranty shall not be enlarged, diminished or affected by, and no obligation or liability shall arise out of, the rendering of technical advice or service by the Company in connection with the equipment. Some states do not allow the exclusion or limitation of incidental or consequential damages, so the above limitations or exclusions may not apply to you. THE FOREGOING IS IN LIEU OF ANY OTHER WARRANTY, EXPRESSED OR IMPLIED, INCLUDING, WITHOUT LIMITATION, ANY WARRANTY OF MERCHANTABILITY AND ANY WARRANTY OF FITNESS FOR ANY PARTICULAR PURPOSE. Some states do not allow limitations on how long an implied warranty lasts, so the above limitations may not apply to you. This warranty gives you specific legal rights, and you may also have other rights which vary from state to state.